

WIRE ROPE USER MANUAL



ushamartin.com

 **usha martin**

USHA MARTIN GROUP

Usha Martin is one of the largest manufacturers of high quality wire ropes in the world.

For more than 50 years, the group has been dedicated to excellence and has implemented stringent process controls at each step of the manufacturing process.

The Usha Martin Group, with its own coal and iron ore mines, 150 MW power plant and over 1 million tons of speciality steel manufacturing capacity, is a truly vertically integrated business. It has a global base of steel wire rope manufacturing facilities located in India, the UK, Thailand and Dubai with service centres spread over all of the key markets in Europe, Asia, Americas and Africa.

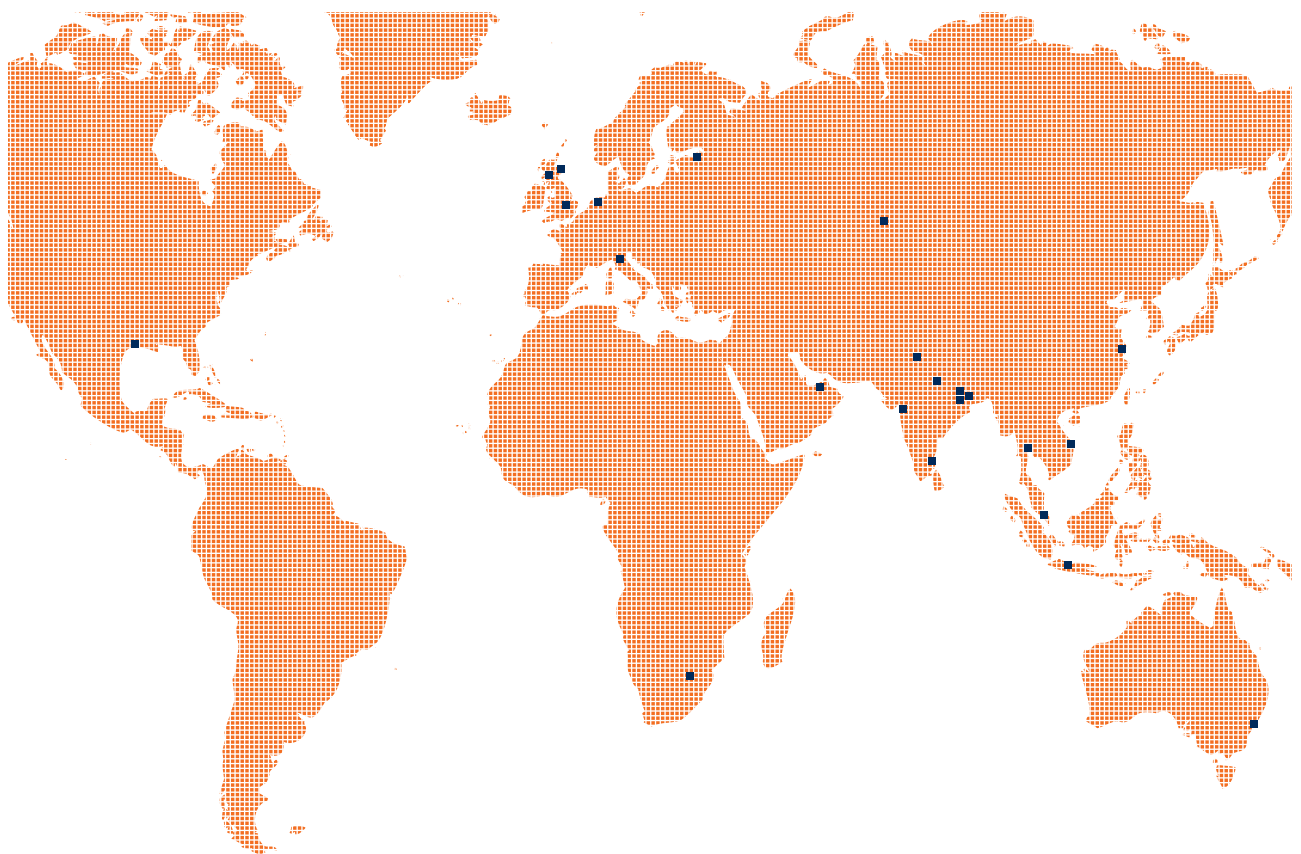

In this world without boundaries, Usha Martin is truly committed to preserve this legacy of quality all over the world and continues to harness its global presence to deliver the best possible solutions for its customers.



List of topics

Preface about rope use	2
Rope diameter and measurement	3
Rope lay measurement and selection.....	4
Strength & breaking force.....	6
Material & surface finish.....	7
Benefits of compacted strands.....	8
Fleet angle and plastic impregnated core ropes.....	9
Rope behaviour under load.....	10
Rotational characteristics.....	11
Block stability and use of swivel	12
Wire rope lubrication.....	14
Reel receipt and storage.....	16
Serving and cutting.....	18
Rope pay out.....	19
Rope terminations.....	20
Socketing operation.....	22
Rope installation and training.....	24
Lifting operations.....	26
Rope winding over sheaves.....	28
Contact pressure between rope and sheaves.....	30
Rope relubrication.....	32
Bending fatigue.....	33
Factors affecting bending fatigue.....	34
Guidelines for rope inspection.....	36
Inspection of grooves and sheaves.....	38
Typical rope damages and recommended actions.....	39
Discard criteria for visible broken wires.....	40
Discard criteria for diameter decrease, deformation and corrosion... .	42
Health and safety information.....	44
Appendix A Quick calculator.....	46
Appendix B Definitions.....	47
Appendix C Reference documents.....	51
Appendix D Examples of strands and ropes constructions.....	52

PREFACE ABOUT ROPE USE

A wire rope can be simply considered as an assembly of several strands laid helically in different possible arrangements in order to bear axial loads.

To be fit for purpose, it must also ensure other features, like resistance to side loads, flexibility, handling and stability.

This definition, however, does not cover completely the implications of correct rope design, manufacturing, use and inspection, as the real mandatory requirement must be, in any case, safety compliance, which allows adequate working conditions for men and environment.

To ensure high quality standards, our Company has settled up a complete process, which includes custom design software, state of the art manufacturing equipment and skilled personnel with proven expertise.

Rope integrity management should always be operated by properly trained personnel, who should always refer to general regulations, specific customer standards, local legislation and internal guidance.

The content of this document is a brief abstract of rope characteristics and recommendations for rope use and it is not intended to be all-inclusive; specific matters can be followed with special care to customer needs by our technical departments.



ROPE DIAMETER AND MEASUREMENT

Each rope is first of all characterized by the nominal diameter and oversize, which have to be selected depending on system configuration and reference regulations.

According to EN12385-1, ISO and API standard, diameter measurement has to be taken on a straight portion of the rope, either under no tension or a tension not exceeding 5% of the minimum breaking force, at two positions spaced at least one metre apart. At each position two measurements, at right angles, of the circumscribed circle diameter shall be taken. The most suitable measuring equipment is plate gauge, capable to cover at least two strands (see Figure 1).



Figure 1 Diameter measurement

Diameter must be measured and recorded immediately after rope receipt, as this value has to be used as a baseline for following inspections.

It has always to be considered that the actual diameter of the rope changes during use due to initial stabilization, to the effect of working tension and to wear generated by the passage over the reeving system.

Permanent diameter reduction after first pull can vary from 0.5% to 3% depending on rope and core construction.

Diameter measurement is an essential tool which can give an immediate and simple evaluation of the overall condition of the rope.

For example, a localized diameter variation can indicate undesired phenomena like geometrical deformation, core distortion or presence of heavy corrosion, while a distributed diameter reduction can be associated to wear due to intensive use. Ovalization is also a marker of possible rope issues which have to be properly addressed.

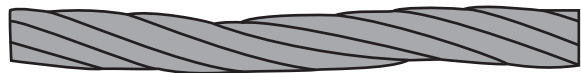

Figure 2 Sunken strand and associated diameter reduction

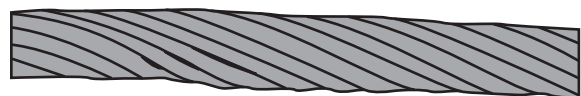

Figure 3 Core distortion and associated diameter increase

ROPE LAY MEASUREMENT AND SELECTION

Lay length represents one of the key characteristics of the rope and affects its elasticity and performance under load. It has to be periodically measured, as possible variations can indicate rope issues, like forced rotation during installation, or unlay due to excessive lifting height, or misalignment of the reeving components.

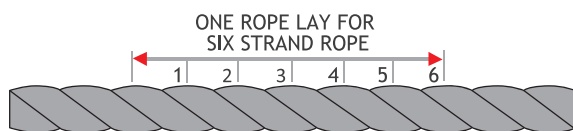

Figure 4 Lay length measurement for a six strand rope

The choice of a Lang or regular lay rope has to be based on rope use and desired performance. Lang lay ropes (i.e. ropes having same direction as the outer strands) give better stability to side wear (phenomenon also known as “crushing”) as the contacts between the wires of adjacent rope wraps are smoother. They are particularly indicated up to 40 mm size ropes used on deck cranes or small winches. Regular lay ropes (i.e. ropes having opposite direction in respect of the outer strands) ensure improved rotation stability and are therefore recommended for relevant lifting height or high capacity cranes.

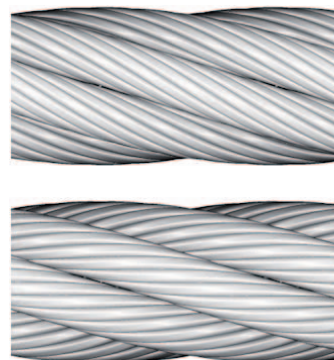

Figure 5 Lang lay (first figure) and regular lay (second figure)



The natural tendency of the rope to twist must be in accordance with the direction of drum winding to get a tight contact between adjacent wraps, especially on the first layer.

In case of plain drum, right hand or left hand lay direction must be selected in order to match the drum's type and direction, as shown in the figure.

These indications are not strictly required for grooved drums, as in this case the rope is already guided by the grooves themselves.

In case of grooved multilayers drums, lay direction can be selected to facilitate the first layer spooling or optimized considering the rope layer that will be more frequently used during operations.

In case of grooved drums, an adequate number of safety wraps should remain in place to avoid rope slipping, while in case of plain drums the whole first layer should never be used, as it works as a bedding for the following layers. Painting the first layer or the safety wraps is a good practice to clearly detect the use of a forbidden portion of rope.

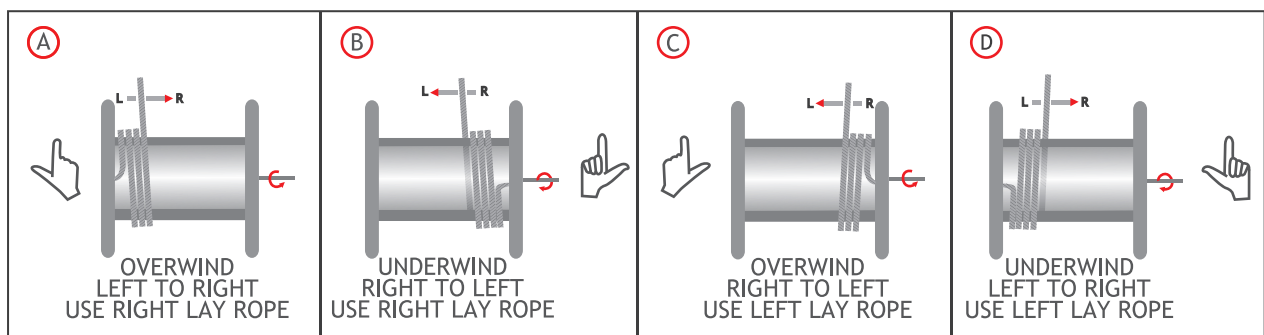

Figure 6 Selection of lay direction

STRENGTH & BREAKING FORCE

A fundamental requirement for wire ropes is the achievement of the minimum breaking force that complies with the crane or winch safe working load.

Rope breaking force can be seen as a function of metallic area, strength and spinning factor. These elements must be carefully combined to confer reliable mechanical properties. Metallic area depends on geometrical construction, diameter oversize and compacting level, strength is dependent on the characteristics of the individual wires, and spinning factor is dependent on manufacturing skill, geometrical construction and compacting level.

However, it must be emphasised that a high breaking force in itself is not sufficient to ensure safe working conditions.

These can be achieved if it is possible to detect within an acceptable time scale that the rope is approaching the end of its useful life or that the prescribed payload has been exceeded.

Good quality ropes must be composed of ductile wires, which will break gradually following remarkable plastic deformation. These gradual breaks will be clearly noticeable by a competent person with responsibility for rope integrity management.

Ropes that rely solely on the use of extremely high strength wires for their breaking force can have severe implications in terms of safety, as the wires will have the tendency to break suddenly without giving proper notice of arising problems.

The graph below compares the behaviour of wires with different strengths: the first figure represents a brittle trend typical of high strength steel (over 2160 N/mm²). The second figure represents the typical trend of lower strength steel (1770 and 1960 N/mm²).

It is therefore essential to adopt the minimum possible strength level and to achieve the desired breaking force by a combination of high compacting level, finely tuned geometrical construction and manufacturing reliability.

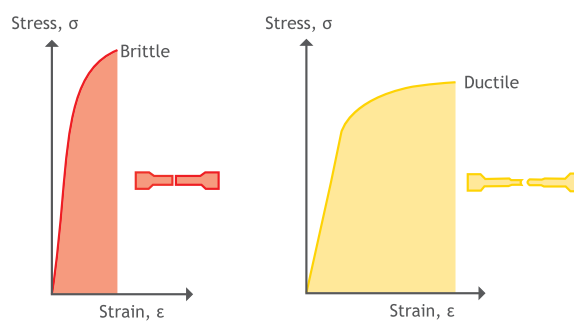

Figure 7 Stress - strain curves



MATERIAL & SURFACE FINISH

Correct selection of raw material is essential in order to get the required breaking force and mechanical characteristics.

Our wire ropes are manufactured using a high carbon content, patented rod, which allows to achieve high rope grades without the adoption of extreme wire strength.

The rod is subjected to a drawing process, which consists of a number of passages through a series of tungsten carbide dies with a gradual diameter reduction. During this process, the metallurgical structure of the rod changes from a very thin perlite pattern to well aligned fibres with high tenacity and strength.

The combination of carbon content and amount of drawing is determined depending on the specific application of the wire rope and the required mechanical characteristics.

Steel has to be protected against corrosion and consequently bright ropes, which are still popular for some applications, have a very limited use in oil and gas applications, while zinc coating is highly recommended for the marine environment.

The quantity of zinc which has to be applied to wires is regulated by EN10264-2 - Steel wire and wire products - Non ferrous metallic coatings on steel wire - Zinc or zinc alloy coatings. For rope used within the oil and gas industry, the typical zinc thickness is approximately 20 to 25 microns, which complies with class B.

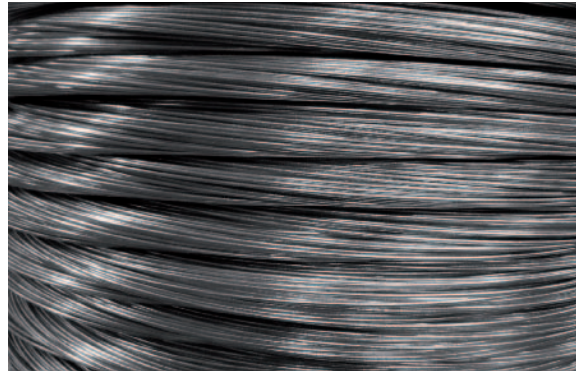

Figure 8 Galvanized wire

Zinc is applied by a hot dip process in order to avoid hydrogen embrittlement typical of electrochemical plating. Hot dip galvanizing creates a tight connection between zinc and steel, virtually alloying them in one unique entity. For severe environmental conditions, improved surface finishing based on zinc aluminium alloys can also be adopted.

It must be emphasised that surface finishing has to be adopted in conjunction with adequate lubrication and maintenance levels in order to preserve wire rope performance.

BENEFITS OF COMPACTED STRANDS

Ropes for heavy lifting and special applications require a high load efficiency and breaking load, which cannot be achieved using traditional round strands. For this reason, these ropes are typically composed of compacted strands, where the level of compaction can be designed and modulated depending on specific requirements.

Compacted strands are created by passing through a die or a series of rollers situated just after the closing point of the stranding machines as shown in the figures.

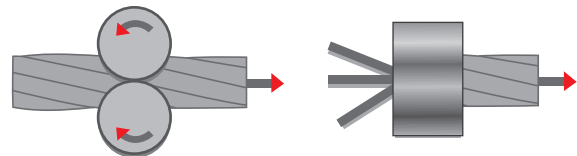

Figure 9 Compacting process through rollers or die

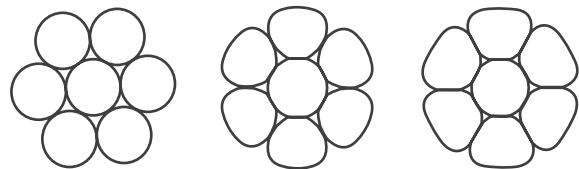

Figure 10 Round strand, light and high compacting level

The main benefit achieved by use of compacted strands adoption is the increase of metallic area in respect to round strands, which leads to higher breaking force. Moreover, compacted strands allow to achieve higher cooperation level of the individual wires, homogeneous and stable strand diameter, resistance to side pressure, wear and abrasion.

Finally, the smoother contact surface between the strands and rounder profile gives better spooling performance and resistance to crushing.

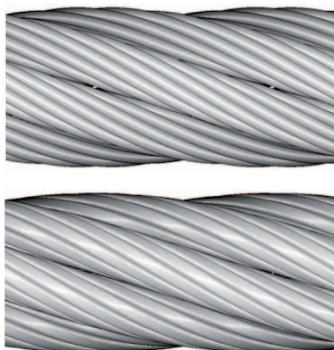

Figure 11 Round strand versus compacted strand

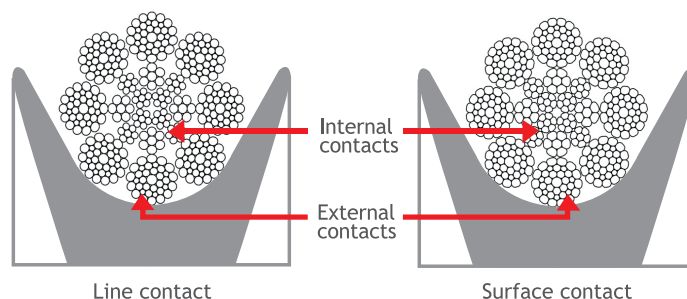

Figure 12 Contact surfaces for a non compacted and a compacted rope



FLEET ANGLE AND PLASTIC IMPREGNATED CORE ROPES

Rope routing must be carefully considered to prevent early damage: one of the most critical factors is the presence of deflection (i.e. fleet) angles between two sheaves or from the drum to the spooler.

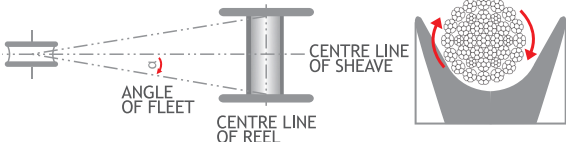

Figure 13 Fleet angle during spooling and rope rolling

When fleet exists, the rope is induced to roll and slide into the groove, causing shortening and increasing of the lay length and possible permanent distortion of the rope structure, such as birdcage or core protrusion.

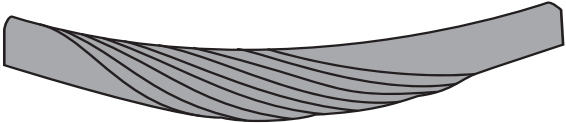

Figure 14 Birdcage deformation



Figure 15 Core protrusion

Fleet angle should never exceed 2° , it can be increased up to 4° with the adoption of plastic impregnated core ropes.

In this type of ropes, plastic is applied to the core after its closing and is lightly heated and softened before final closing in order to create a connection between outer strands and core strands.

The plastic layer must not work as a cushion (see left sketch), but must allow steel over steel contact between the core and the outer strands (see right sketch). This ensures long-lasting radial stiffness and rope stability.

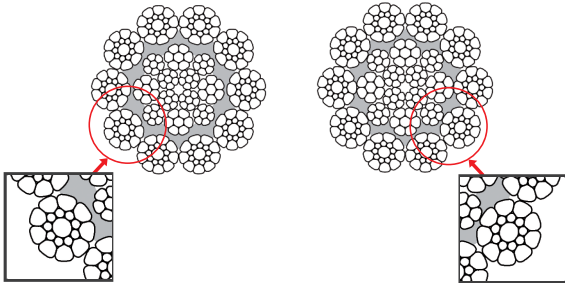

Figure 16 Cushion layer versus plastic impregnated core

ROPE BEHAVIOUR UNDER LOAD

When a rope is subjected to axial loads, the elasticity of the material causes elongation and consequential diameter reduction.

The first graph shows the relationship between stress (ratio between load and metallic area) and strain (ratio between elongation and initial sample length). The slope of the curve is Young modulus “E”, which multiplied by the metallic section “A” gives the axial stiffness “EA”.

In the first phase of its use (up to point 1), rope shows a certain permanent stretch due to the stabilization of the individual wires.

After this step, the trend is basically linear up to the achievement of yield point (points 3 and 4), from which permanent plastic deformation takes place, until the load reaches the actual rope breaking force.

A typical example of relationship between rope oversize (ratio between actual and nominal diameter) is indicated in the second graph.

After training, every rope shows a permanent diameter reduction due to the stabilization of its structure. The initial diameter and the consequent reduction must be such to allow smooth installation on the drum and good spooling.

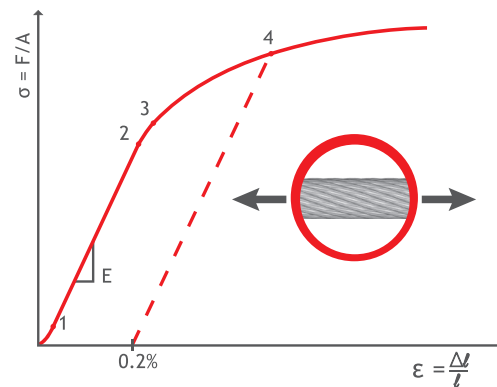

Figure 17 Stress - strain curve for a wire rope

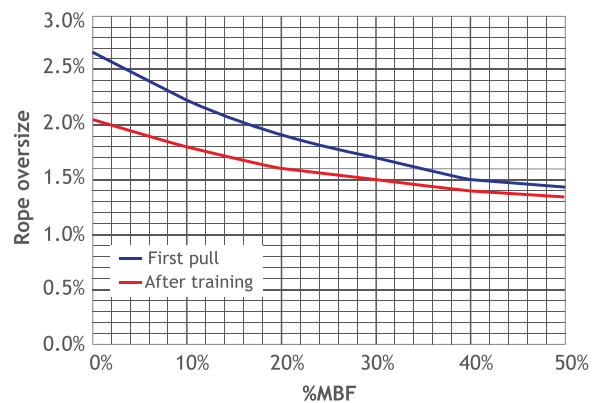

Figure 18 Rope oversize versus load



ROTATIONAL CHARACTERISTICS

Being composed by helically laid elements, each rope has the natural tendency to twist when subjected to axial loads.

The level of twist is dependant on the geometrical arrangement and can be reduced by compensating the core tendency to rotate in one direction with an opposite tendency of the outer layer, as typically applied to spin resistant and non rotating ropes.

Ropes are conventionally classified based on the number of turns that a portion with length of 1000 times the nominal rope diameter would make when pulled at 20% MBF (see figure):

1. Non rotating: less than 1 turn
2. Low rotation: from 1 to 4 turns
3. Spin resistant: from 4 to 10 turns
4. Not non rotating: more than 10 turns

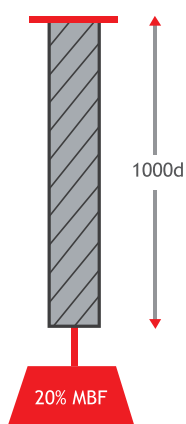

Figure 19 Rope classification based on number of turns

Each rope is characterized by torque factor, which is used in the calculations when both ends of the rope are fixed, and rotation factor (expressed in degrees/lay), which is used when one end is free to rotate.

Both torque factor and rotation factor strongly decrease after rope stabilization and are negligible if the rope is always used at same working load and lifting height.

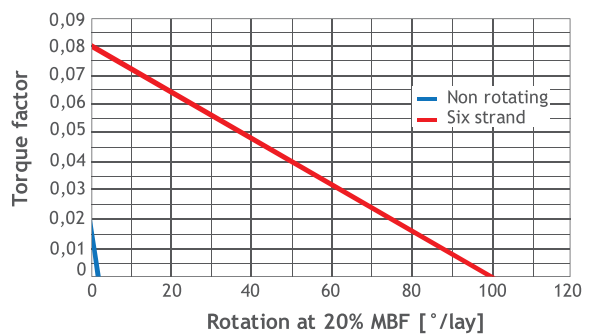

Figure 20 Torque factor for non rotating and six strand ropes

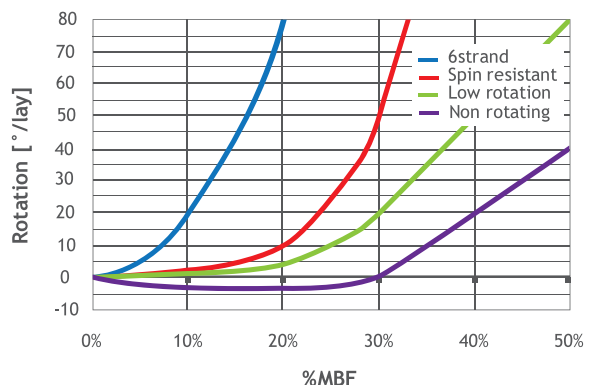

Figure 21 Rotation for different rope constructions

BLOCK STABILITY AND USE OF SWIVEL

In case of single fall lifting a non rotating rope is typically recommended, while in case of multi-part reeving arrangement, rope type has to be selected depending on height of lift, block configuration and loading.

A wrong rope selection or improper installation and training can cause cabling phenomenon, which can lead to permanent rope deformation, like waviness, and severe operations issues.

The maximum lifting height for a given rope torque factor “t” can be briefly calculated using the approximate formulas shown in the sketch (all dimensions are in m).

In case of special block arrangement, please contact us for a custom evaluation.

When operating a non rotating rope in single fall mode, a swivel can be used to relieve the rope of any induced rotation resulting from angular deflections at a sheave or drum.

Swivels must not be used with not non rotating ropes, like 6 strand, as it would cause rope unlay, severe reduction of its breaking force and secondary fatigue of the steel core, not detectable during inspections.



Figure 22 Multiple fall lifting



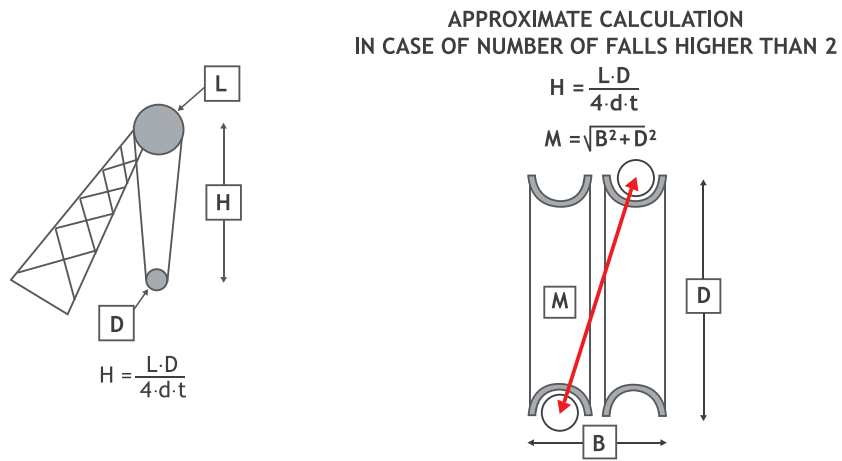

Figure 23 Calculation of maximum lifting height

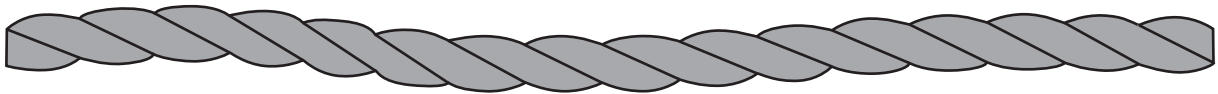

Figure 24 Rope waviness



Figure 25 Example of swivel

WIRE ROPE LUBRICATION

Proper lubrication is essential to maintain rope performance in use, protect it against corrosion and preserve its service life.

Good quality lubricants are characterized by high adherence to steel in order to withstand passage over the reeving system, light colouring which will not obstruct the detection of possible rope damage and high compatibility with other products, which is particularly important for vessels operating globally.

Drop point has to be high enough to tolerate rope storage and operation in warm environment, but with a safety borderline that is sufficient to detect rope overheating during the use of special devices such as heave compensators. Since steel can suffer permanent deterioration if subjected to high temperatures for extended periods, a good temperature limitation and consequent drop point is approximately 80° C.

Lubricant can be applied during different manufacturing phases: stranding, core closing and final closing.

When applied during stranding, the lubricant is firmly engaged within the rope structure and reduces friction between the wires. If applied during core closing it creates a barrier against external elements penetration and if applied during final closing it further increases protection against corrosion.

The quantity of lubricant applied during rope manufacture has to be carefully evaluated on the basis of rope use and working environment.

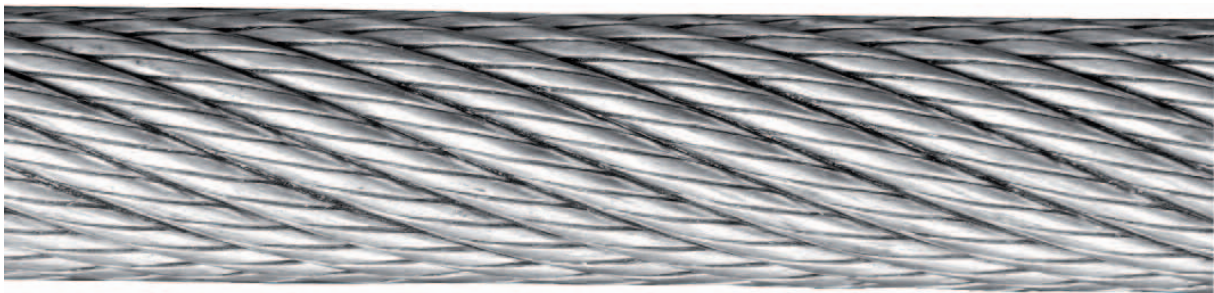

Figure 26 Example of rope with very low outer lubrication



If insufficient lubricant is applied, the rope will not be adequately protected, however an excess of lubricant may be squeezed out of the rope during installation and use, thereby creating environmental and safety issues. This has to be carefully considered in case of boom hoist ropes operating on offshore vessels, which run over reeving systems composed of a high number of sheaves. Before rope installation and during rope use, the lubrication level must be periodically inspected to detect any overall or localised faults and, where required, relubrication can be performed by using appropriate pressure devices. For ropes operating subsea, lubricant should be applied during deployment in order to fill the strands gaps and prevent water penetration and trapping.

The most typical levels of lubrication are shown in the following figure:

- the first image refers to very small size ropes, with lubrication applied only during stranding
- the second figure refers to ropes for industrial lifting, with lubrication applied during stranding and core closing
- the third figure refers to ropes for marine environment applications, with lubrication also applied during final closing operations. This is the most frequent option for oil and gas applications
- the fourth image shows a very high amount of lubricant, required for ropes operating subsea or dealing with very severe environmental conditions

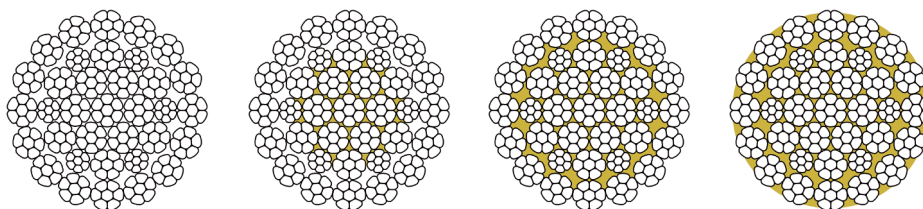

Figure 27 Typical lubrication levels

REEL RECEIPT AND STORAGE

After receipt, the rope should be immediately checked to verify its identity and condition and should not be used without the possession of adequate documentation and certificates. The Certificate of Conformity by the manufacturer should be stored in a safe designated place in order to quickly identify the rope and carry out periodic inspections.

During loading, transferring and unloading operations, rope reels or coils should be properly handled using slings or lifting beams.

Slings must have an adequate length to avoid flange ends overstress during reel lifting.

The rope should be checked to verify that it is not damaged when unloaded and transported to storage site and should not come into contact with parts of the lifting devices, like hooks and forks.

Some recommendations for rope handling are indicated on specific labels applied on the reels.

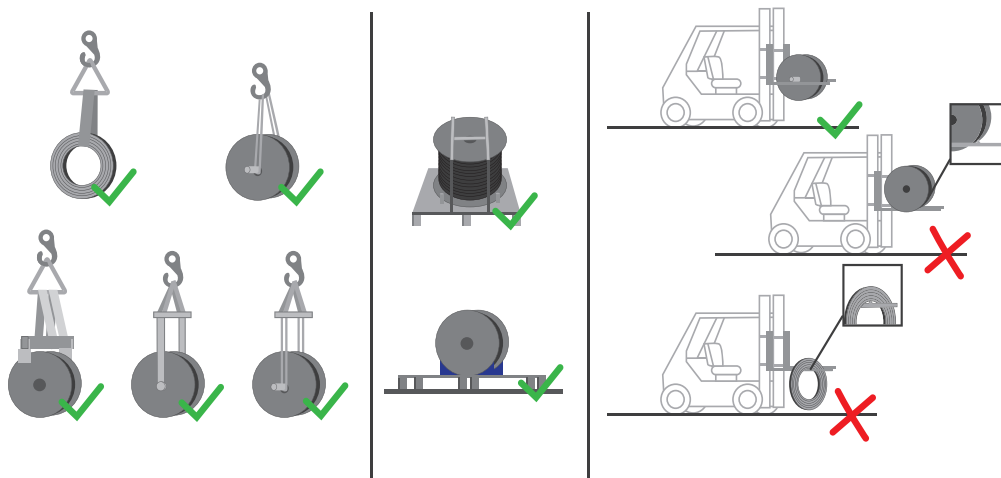

Figure 28 Rope handling recommendations



Storage conditions are essential to prevent rope damage: it should be avoided to keep the rope in very warm or humid environment, as this could break down the effectiveness of native lubrication and accelerate the deterioration process. If lubricant has the tendency to drain due to high temperature, the reel should be periodically rotated to maintain a homogeneous distribution.

The rope should not be stored in places which could be affected by chemical agents, corrosive matters or accidental damages and, if stored outside, the reel should be positioned in order to avoid direct contact with the ground and covered with waterproof material.

The rope marking should be clearly detectable and readable in order to safely and quickly identify the reel.



Figure 29 Reel handling

SERVING AND CUTTING

During manufacturing process, the strands can be preformed in order to get a helical profile just before closing and improve rope stability and handling. Similar purpose can be achieved through postforming, which consists of the passage of the rope through a series of rollers. With the exception of very specific applications, preforming and postforming level must be such to stabilize the rope without reaching extreme levels, as this would make the rope very faint during use.

Therefore, unless the rope has been subjected to complete preforming, it will have the tendency to unlay when cut.

For this reason, serving shall be applied before rope cutting to keep strands in position and it has to be performed carefully, as its failure may cause injuries or rope permanent damages. Serving must be also performed before socketing and in this case it has to allow socket medium penetration between the rope and the socket bore. Service length “L” should be at least equal to two rope diameters “d” (see figure).

For preformed ropes one serving is typically enough, while for not preformed ropes, rotation resistant and parallel closed ropes a minimum of two servings is recommended. Serving material shall be tinned or galvanized soft wire or strand for zinc/zinc alloy coated wire ropes, and bright, tinned or galvanized soft wire or strand for bright wire ropes.

Wire diameter shall be such to firmly hold the strands and, particularly in case of large size ropes, seven wires strands can be used as an alternative to single wires.

Before cutting the rope, a clear mark should be applied on the cut area and servings should be applied at each side of the mark.

Depending on its size, the wire rope can be fused and tapered or cut using high speed abrasive disc cutters, percussive or shearing methods, paying particular attention not to disturb the position of wires and strands below the serving. Rope core can be cut with no major issues in case it has the tendency to protrude in respect to the outer layer.

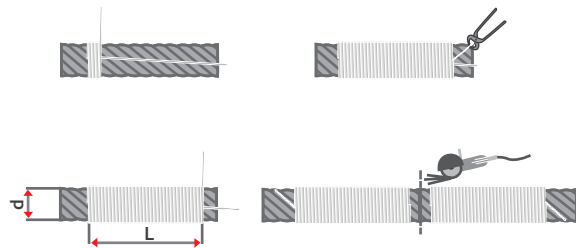

Figure 30 Serving dimensions and configuration

Rope size	Diameter of service wire or strand [mm]	
	Wire	Strand
Up to 22 mm	1.1 - 1.5	1.6 - 1.8
From 22 to 38 mm	1.4 - 1.8	1.6 - 2.5
From 39 to 76 mm	1.6 - 2.0	2.5 - 3.0
From 77 to 100 mm	1.8 - 2.2	3.0 - 3.5
Over 100 mm	n/a	3.5 - 4.0

Figure 31 Typical serving wire and strand dimensions



ROPE PAY OUT

Ropes can be supplied on coils or reels depending on size and customer requirements.

If the rope is supplied on a coil, it should be placed on the ground and rolled out straight, avoiding contamination with dust, grit, moisture or other harmful material.

The rope should never be pulled away from a stationary coil as this will induce turns into the rope and form kinks (see figure).

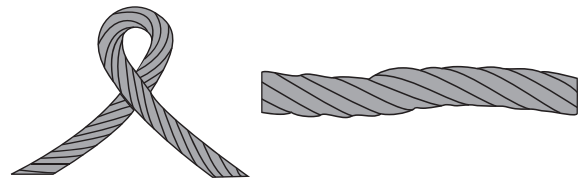

Figure 32 Rope kink and associated deformation

If the coil is too large to be physically handled, it may need to be placed on a turntable to pay it out as the end of the rope is pulled away from the coil.

If the rope is supplied on a reel, a shaft of adequate strength should be passed through the reel bore and the reel should be placed in a suitable stand which allows it to rotate and be braked to avoid overrun during installation.

If a loop forms in the rope it should not be allowed to tighten to form a kink.

The reel stand should be mounted in a way that avoids reverse bend during reeving: for a drum with an underwind rope, take the rope off the bottom of the supply reel.

Underwind is also preferable in respect to overwind, as it gives higher stability to the stand and less risk of overturn.

When releasing the outboard end of the rope from the supply reel or coil, this should be done in a controlled manner.

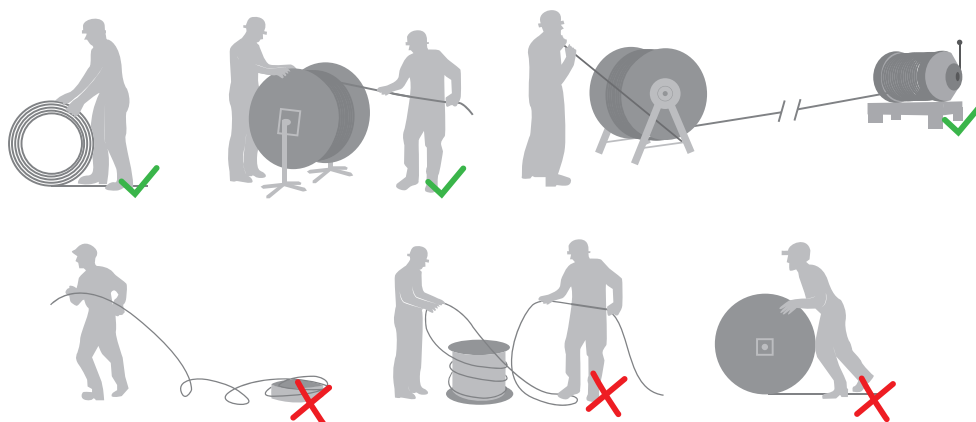

Figure 33 Recommendations for rope pay out

ROPE TERMINATIONS

Ropes can be supplied with different end terminations depending on customer requirements. Temporary end connections must be used only for rewinding or installation, while permanent end connections can also be used for actual operations.

Permanent connections allow the Safe Working Load to be maintained and are characterized by a specific efficiency depending on the connection type, which varies from 100% for resin sockets to 80% for wedge sockets.

Temporary end connections must not be used as lifting devices, as they are not designed to ensure Safe Working Load but only to allow the rope to be moved from the storage reel to another reel or to the winch drum.

Some examples of end connections are shown in the following table. Special sockets or connections can be provided on demand.



Figure 34 Detail of hoist and boom ropes









Temporary	Permanent
Becket loop 	Open spelter socket 
Tapered 	Closed spelter socket 
Bolted eye 	Cylindrical socket 
Chinese finger 	Wedge socket 

Figure 35 Examples of rope terminations

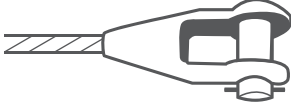
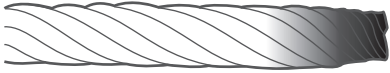
SOCKETING OPERATION

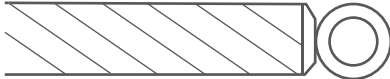
Socketing must be performed by trained people using proper procedures and equipment.

Socketing media can be metal or resin, which is more extensively used due to ease of handling and safety. Moreover, heat generated during metal socketing can affect steel properties of the rope.

According to EN12927, the length of the tapered part of a socket shall be at least 5 times the nominal rope diameter or 50 times the outer wire diameter and the angle between the generatrix and the axis of the cone shall be from 5° to 9° . The socket basket neck diameter shall be from 1,2 up to 1,3 times the rope nominal diameter and shall have a cylindrical portion long from 0,25 up to 0,5 times the rope nominal diameter.

The internal socket profile must not have grooves, as these would reduce resin penetration.

To perform proper socketing, the position of the wires and strands of the non-socketed portion of rope shall remain undisturbed during the socketing operation, therefore adequate servings are required.

Dirt, grease, scale or residues shall be removed from the inside of the socket basket to prevent resin contamination.

After having inserted the rope into the socket, all the individual wires shall be opened to form a brush, which shall be degreased to remove all traces of lubricant and shall be completely dry before the socketing medium is poured into the socket. Wire shall not be straightened when forming the brush, as this would reduce the efficiency of the socketing media.

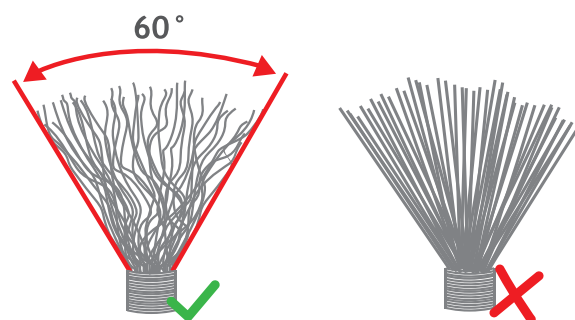

Figure 36 Socket brush



The wires shall be evenly distributed around the circumference within the socket basket and the area where the rope enters the bore of the socket shall be sealed with a material that prevents leakage of resin and that shall be removed after socketing. Before starting the operation, the socket must be aligned with the rope axis.

The operator shall follow the resin manufacturer's instructions, resin system packages or kits shall not be sub-divided or used after the expiry date indicated on the container or out the prescribed temperature range.

The socket shall be filled from a single pouring until the basket is full: the approximate resin content in cc for a standard spelter socket can be calculated using the formula in the sketch (cone dimensions are in cm).

During the pouring and topping-up operation and early stages of gelling, it is essential that possible leaks are identified and stopped, as such leaks may generate cavities near the neck of the brush.

The resin mixture shall be allowed to harden after gelling and the socket shall not be moved until the resin has hardened. Some resins contain a coloring component which turns into blue during gelling.

Wires protruding after hardening due to resin loss of volume helps to verify the proper wires distribution into the cone and does not need to be covered or removed.

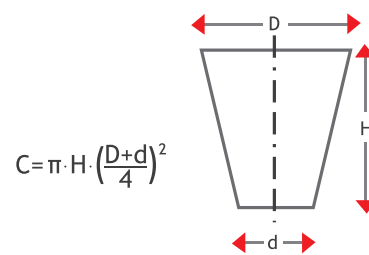

Figure 37 Resin content and cone dimensions

ROPE INSTALLATION AND TRAINING

Rope spooling and installation should be carried out in accordance with a detailed plan issued by the user of the rope to prevent safety hazards and early rope damage.

The installation tension should be at least the highest value between 2% of the rope MBF or 10% of rope SWL.

This tension can be obtained directly using the spooling device or later during training stage, depending on rope size and equipment availability.

Standard rope reels are designed for transportation and storage, therefore they can bear a limited amount of pulling tension, which is approximately 3 times the reel diameter for steel reels, 0.5 times the reel diameter for wood reels (e.g. 1.5 meter steel reel can bear up to 4.5 tons, 1.5 meter wood reel can bear up to 0.75 tons) up to a maximum of 10 tons using two spindles for each flange.

If higher tension has to be applied, the rope has to be spooled on an intermediate reel or special reel requirements have to be agreed with the rope supplier.

When first installing the rope, a pilot line having adequate breaking force to bear the installation pull should be reeved on the system and connected to the rope itself. The pilot line shall have same lay direction and type as the rope to be installed, otherwise twist could be induced and permanent damage could occur.

A swivel should not be used during the installation of the rope.

It is also important to note that there are operational limits related to some rope constructions: as a general guideline, the maximum operating depth is 1300 meters for 6 strand ropes and 1000 meters for 8 strand ropes.

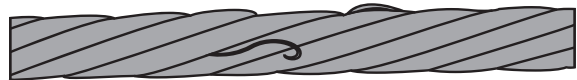

Figure 38 Broken wire due to improper handling



During pulling into the system, the rope should be carefully monitored and it should not be obstructed by any part of the structure that may bring damage and result in a loss of control. The equipment should be run at limited speed to facilitate gradual rope stabilization. Full load should never be applied during this stage.

During spooling, continuous check has to be performed to verify that no slack occurs in the rope or cross-laps of rope develop at the drum, as irregular coiling would inevitably result in severe surface wear and rope distortion. In multilayer drums, the crossover area (see figure) must be carefully monitored. A good spooling will show tight wraps and uniform rope arrangement also in the crossover zone and up to the last layers, which will reduce the risk of crushing, cut-in or early formation of broken wires.

Training is also essential to stabilize rope dimensions and to optimize rope lifetime and performance.

It is performed by lifting an adequate load for at least three times using the full rope length, excluding the safety wraps which must always remain on the drum: the load automatically generates proper backtension, diameter stabilization and torque factor reduction.

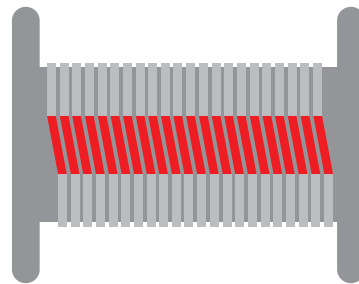

Figure 39 Crossover area

LIFTING OPERATIONS

Applicable regulations give indications to ensure that lifting equipment is safe when new, that it is used safely and that it remains safe for use.

Equipment and accessories are marked with their own safety working loads and must never be used out of the prescribed interval. They should always be thoroughly examined according to adequate inspection procedures, as well as before first use, when moved to different locations in respect to the original one and each time unexpected events which may affect safety occur.

Similar indications apply to wire ropes, which should always be handled, maintained and inspected by competent persons using proper procedures (see also chapters related to wire rope inspection).

When bent over stationary pins or sheaves, rope minimum breaking force is affected in respect to linear load conditions depending on D/d ratio, thus reducing its efficiency (see figure).

For moving parts, further reduction must be considered due rope internal friction and efficiency of the rotating parts.

The efficiency of sheaves should also be considered when calculating the lead line load. In case of systems having same number of rotating sheaves and parts of line (e.g. 2 falls and two rotating sheaves, like in the first sketch), the lead line load can be calculated by dividing the load by the efficiency coefficient (e.g. as per the following table: lifting 80 tons in 2 parts mode with roller bearing sheaves will give a lead line load of $80 / 1.94 = 41.2$ tons). If additional rotating sheaves are used (see second sketch), unless otherwise specified the resulting line load should be divided by 0.96, 0.98 or 0.99 (plain, roller bearing or high efficiency sheaves) times the number of extra sheaves in respect to the rope bearing parts.



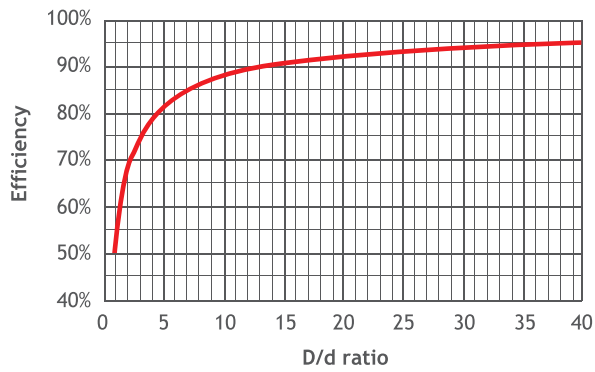

Figure 40 Reduction in rope efficiency in case of bent over stationary components

Parts of line	With plain bearing sheaves	With roller bearing sheaves	With high efficiency sheaves
1	0.96	0.98	0.99
2	1.87	1.94	1.97
3	2.75	2.88	2.94
4	3.59	3.81	3.90
5	4.39	4.71	4.85
6	5.16	5.60	5.80
8	6.60	7.32	7.65
10	7.91	8.98	9.47
12	9.11	10.6	11.3
14	10.2	12.1	13.0
16	11.2	13.6	14.7
18	12.2	15.0	16.4
20	13.0	16.4	18.1

Figure 41 Example of lead line factors

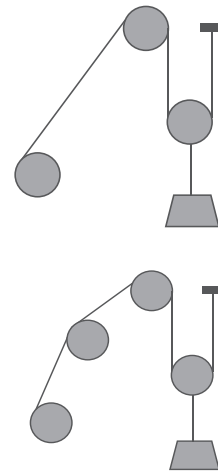

Figure 42 2 Falls with 2 rotating sheaves and with an extra sheave

ROPE WINDING OVER SHEAVES

When a rope runs over the reeving, its strands are forced to modify their relative position to maintain contact with the system.

If the reeving arrangement is not properly designed, the strands cannot recover their natural location in the passage between adjacent components, therefore the rope can suffer premature fatigue or localized damage. This particularly applies in case of reverse bending configuration, where the strands are stretched and compressed between two sheaves. To avoid permanent damage, for complete reverse bending (see first sketch) the minimum recommended distance is about 100 times the rope diameter.

For partial reverse bending (see second sketch), a lower distance could be accepted. Both in the case of reverse and simple bending, the sheaves have to be properly designed in terms of size, groove configuration and hardness.

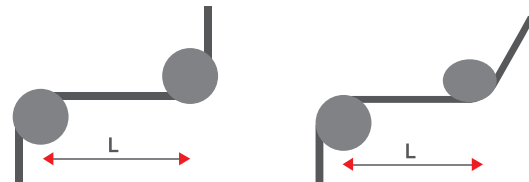

Figure 43 Reverse bending and partial reverse bending



Figure 44 Detail of rope winding



As already mentioned, the typical minimum recommended bending ratio is 20 times the rope nominal diameter, while the recommended groove oversize can vary from 1.06 to 1.1 times the rope diameter.

In order to allow a smooth contact surface, the rope should be in touch with the sheave for at least 1.5 times its lay length, which corresponds approximately to a 60° winding angle for a sheave having a bending ratio of 20.

For very small winding values the stress induced to the rope is not very relevant, while in the intermediate range, from 10° to 45°, significant damage can occur, especially if the component is located in the high tension side of the reeving.

This figure does not apply in case of rollers or sheaves with reduced bending ratio (up to 10), since the rope has to deal with a relatively small bending ratio.

In this case, it is always recommended to adopt a minimum bending ratio equal to the winding angle (e.g. 2 D/d minimum in case of 2° winding angle).

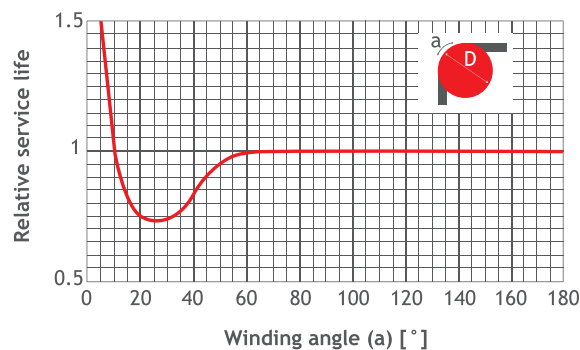

Figure 45 Relative service life depending on winding angle

CONTACT PRESSURE BETWEEN ROPE AND SHEAVES

When the rope is bent over a component of the reeving system, it generates pressure which is dependent on its diameter, the diameter of the component itself and the applied tension.

In order to ensure proper performance, the groove material should give a smooth and hard contact.

In case of inadequate material selection, the groove steel will be locally hardened, with consequent embrittlement and detachment of steel flakes, which can damage both the rope and the component itself.

The typical recommendation is to use hardened steel with approximate 300 HB value.

In case of synthetic sheaves, the yield point of the material should be higher than the exerted pressure.

The nominal average pressure can be calculate using the formula shown in the next page.

Multistrand and non rotating ropes ensure a better pressure distribution than six strand ropes, as the higher number of outer strands generates a wider contact surface (see figures of the next page).

Compacted strands and Lang's lay ropes further extend the contact surface.

A good groove dimension is also important to achieve a reduced pressure.

The figures of the next page show different configurations depending on various groove oversize: narrow, well dimensioned and large groove.



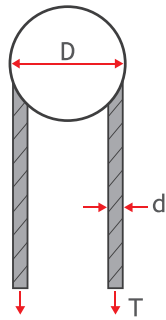

$$P = \frac{2T}{Dd}$$

P = pressure [N/mm²]
 T = rope tension [N]
 D = diameter of sheave or drum [mm]
 d = diameter of rope [mm]

Figure 46 Rope pressure over a sheave

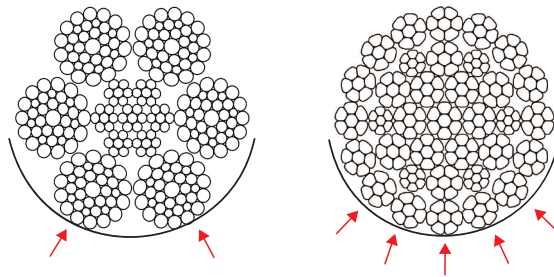

Figure 47 Pressure distribution of 6 strand and non rotating rope

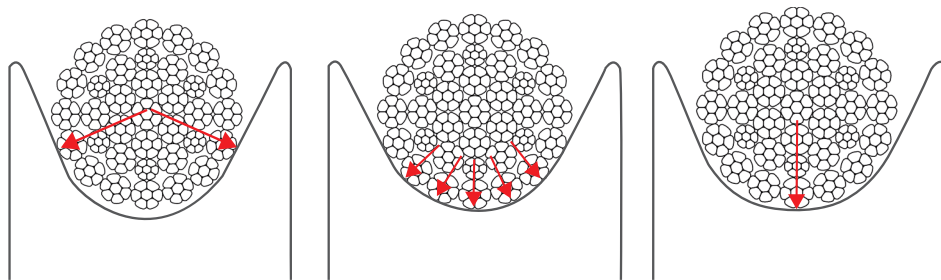

Figure 48 Pressure distribution for narrow, well dimensioned and large grooves

ROPE RELUBRICATION

The main purpose of lubrication is to maintain rope performance in use and protect it against corrosion, which can determine rope discard when reaching a high severity rating. Corrosion affects not only the residual breaking force, but also wire ductility and mechanical characteristics, therefore it should be carefully considered when inspecting a rope. Unless unexpected events, the protection provided by the original manufacturing lubricant is enough to prevent rope corrosion during shipment, storage and first period of use. Lubricant conditions must be periodically checked depending on rope working type and environmental conditions.

Before relubrication, rope must be cleaned to remove scales, moisture and other contaminants. Lubrication must be carried out on dry and clean rope using a lubricant compatible with the original one and whose amount is not excessive, as this would make difficult to inspect the rope and could lead to accumulation of debris which could generate abrasions. Some typical lubrication modes are shown in the following figure.

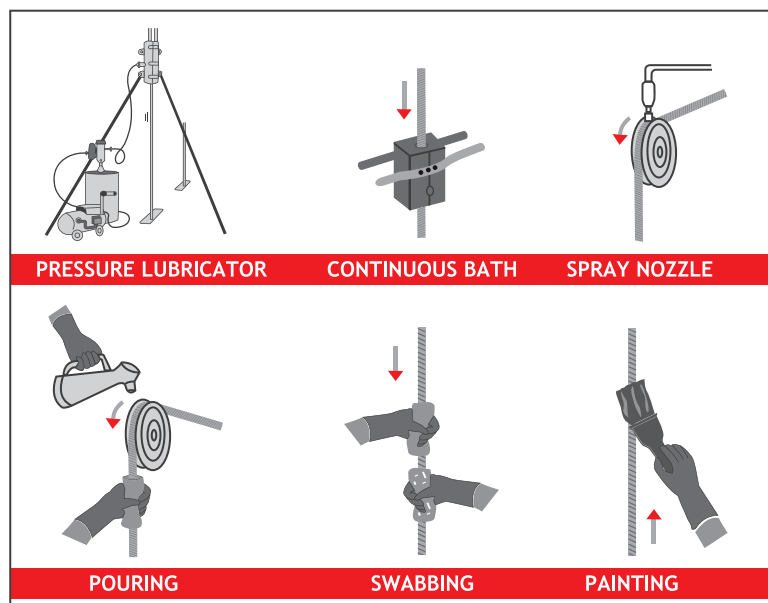

Figure 49 Typical lubrication modes



BENDING FATIGUE

Fatigue damage is a typical phenomenon which is not caused by a single event, but by repeated bending, tension and rotational stresses: since the working life of wire ropes generally involves several passages over drum and sheaves, this damage has to be carefully considered during operations.

The first factor to be considered with respect to fatigue damage is the working load: taking a safety factor of 5 as a reference point, relative service life of rope operating in the same system with different loads is shown in the first figure. Fatigue damage occurs gradually and becomes evident when it reaches a point where it has caused a high number of broken wires and consequent wire elongation, which quickly evolves until the rope gets to discard criteria. The typical trend of fatigue growth is shown in the second figure: it is clear that there is a rapid increase in the curve slope after a certain threshold, and this is strongly affected by working load.

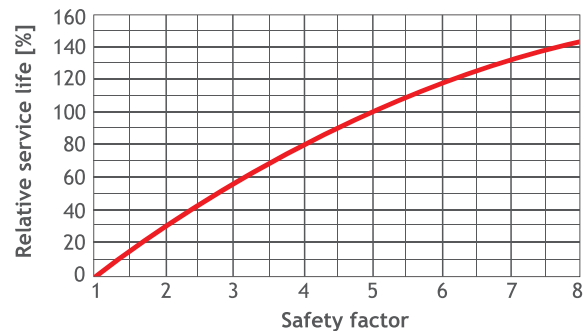

Figure 50 Effect of safety factor on service life

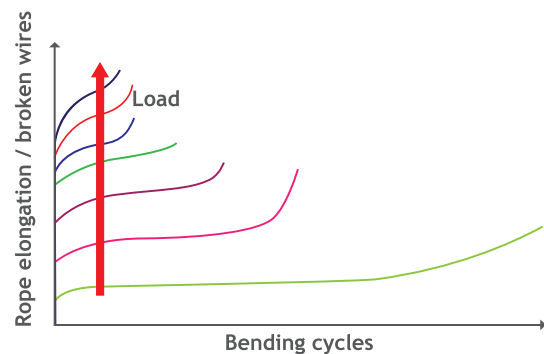

Figure 51 Fatigue progression

FACTORS AFFECTING BENDING FATIGUE

Since fatigue is an inherent phenomenon, it cannot be eliminated, however it can be slowed down by adopting, when possible, particular features with respect to rope design and system layout.

With respect to rope design, the most effective way to reduce fatigue evolution is by avoiding the use of extremely high strength wires (over 2160 N/mm²).

As already mentioned, this improves steel ductility allowing a better resistance to repeated bending cycles.

Contrary to expectation, rope composed of many small wires may not have higher fatigue resistance, especially when working at low safety factor.

In terms of system design, there are several strategies that can be adopted to preserve rope life.

The first tool is to increase the bending ratio of the component over which the rope is running.

This can have some practical limitations, especially when dealing with large size ropes. Another approach which can be adopted without major expense is the selection of proper groove size. The recommended value is approximately 1.08 times the nominal rope diameter, depending on rope type and possible fleet angle.

Fleet angle must be always considered and limited, as it creates a stress within the structure of the rope and contributes to fatigue build up.

In case of fleet angle, groove oversize should be increased to 1.10 or more in order to facilitate the passage of the rope through the groove.



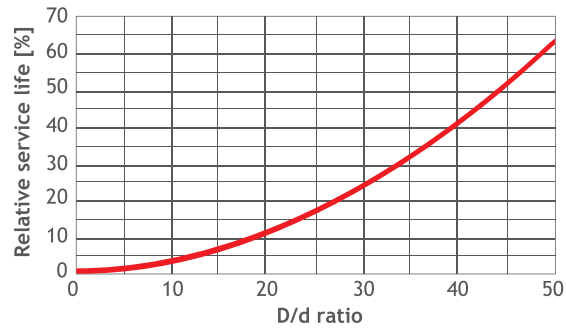

Figure 52 Effect of bending ratio on service life

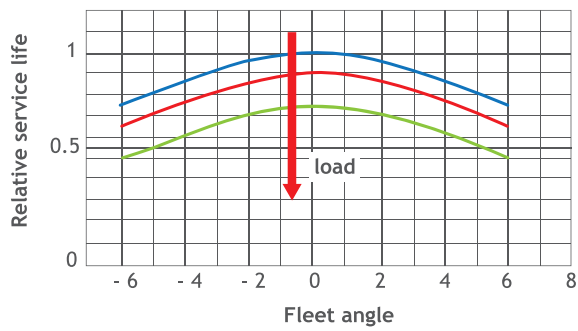

Figure 53 Effect of fleet angle on service life

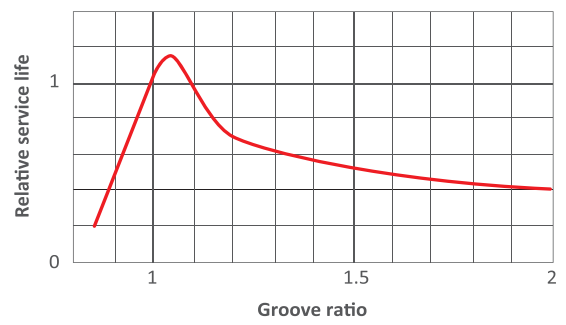

Figure 54 Effect of groove ratio on service life

GUIDELINES FOR ROPE INSPECTION

Wire ropes must be periodically inspected following regulations (e.g. ISO 4309) and internal procedures to assess rope deterioration due to regular use or unexpected events and to ensure safe working conditions.

Inspections can be carried out with the aid of visual or magnetic devices: in this case, it is recommended to perform an initial inspection before rope use to have a baseline for future comparisons.

Each rope shall be inspected along its entire length or, at the discretion of the competent person, along the working length plus at least five wraps on the drum. In this case, if a greater working length is subsequently foreseen to be used, that additional portion should also be inspected.

The frequency of inspections depends on regulations, type of crane and environment, results of previous examinations, load spectrum and experience related to similar ropes and systems.

The main modes of deterioration are: broken wires or strands, decrease in rope diameter, corrosion, deformation, mechanical or heat damage and change in elastic behaviour of rope under load.



Figure 55 Ropes used for construction cranes



The following areas have to be inspected with particular care:

- drum anchorage and any section close and in correspondence to rope termination
- in case of repetitive operations, any part of the rope that lies over a sheave during crane working
- rope portion which lies over a compensating sheave
- cross-over zones on multilayer drums
- rope sections subjected to reverse bending over sheaves or rollers
- section subjected to external damage, like abrasion or heat.

Terminations, clamps and securing ferrules should be also inspected with special care to detect possible looseness due to vibrations, cracks, distortion, wear or corrosion.

After each periodic inspection, the competent person shall provide a rope inspection record and state a maximum time interval that shall not be exceeded before the next periodic inspection takes place.

The following sketch shows some examples of typical points which require special care during inspection.

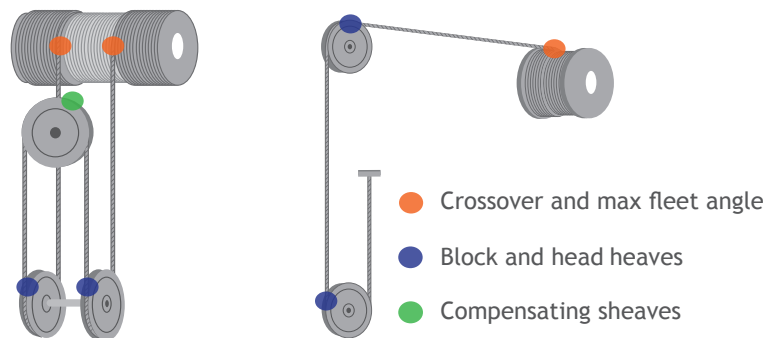

Figure 56 Areas requiring detailed inspection

INSPECTION OF GROOVES AND SHEAVES

Before installing the new rope, the condition and dimensions of interface parts, like drums, sheaves and rope guards, should be checked to verify that they are within the operating limits as specified by the original equipment manufacturer.

The groove diameter, which can vary from 5% to 10% above the nominal rope diameter, should be checked using a sheave gauge (see figure). Sheaves should also be checked to ensure that they are free to rotate.

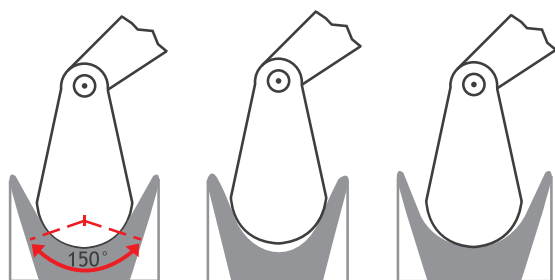

Figure 57 Grooves inspection: correct size, narrow and large groove

When grooves become excessively worn, they can be re-machined if sufficient wall thickness will remain in the underlying material after the machining has been carried out.

Improper groove finishing can generate irregular rope routing and derailing over the sheave.

The recommended bending ratio D/d (e.g. ratio between diameter of the component and rope nominal diameter) depends on rope construction. Some typical values for crane applications are shown in the following table and are determined based on uniform stress distribution of rope, strands and individual wires.

Other values can be found on specific regulations.

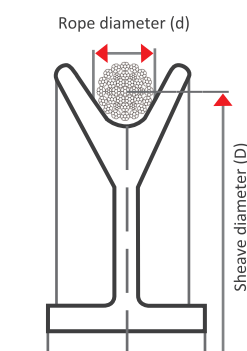

Figure 58 Bending ratio between rope and sheave

Construction	Suggested D/d ratio
6 x 46, 8 x 36	18
19 x 19, 35 x 7, 6 x 41, 8 x 25	20
6 x 36	23
8 x 19, 6 x 25, 6 x 31	26
19 x 7, 6 x 19	34

Figure 59 Examples of recommended bending ratios for cranes



TYPICAL ROPE DAMAGES AND RECOMMENDED ACTIONS

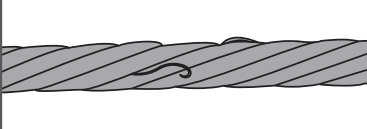

Wire protrusion
Cause Improper rope handling
Ref. ISO4309 - 6.6.5
Action Discard [can be removed for limited use]

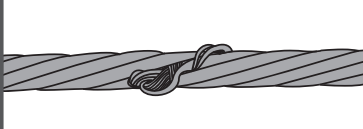

Core protrusion
Cause Fleet angle, shock loading
Ref. ISO4309 - 6.6.4
Action Immediate discard

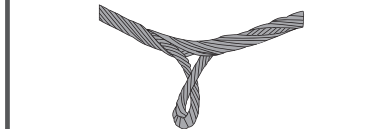

Protrusion of inner rope
Cause Fleet angle, shock loading
Ref. ISO4309 - E.4 c)
Action Immediate discard

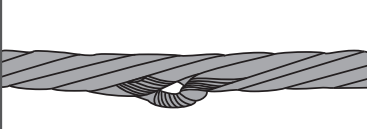

Strand protrusion or distortion
Cause Forced twist
Ref. ISO4309 - 6.6.4
Action Immediate discard

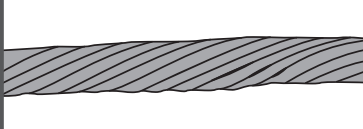

Local increase in rope diameter
Cause Fleet angle
Ref. ISO4309 - 6.6.6
Action Remove the cause and monitor the evolution

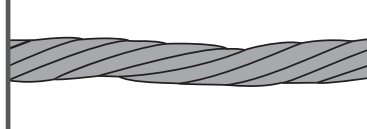

Local reduction in diameter
Cause Core break
Ref. ISO4309 - 6.3
Action Immediate discard

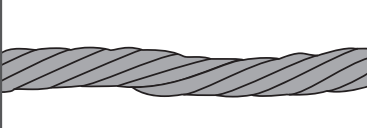

Kink (positive)
Cause Fleet angle, forced rotation
Ref. ISO4309 - 6.6.8
Action Immediate discard

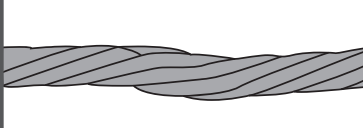

Kink (negative)
Cause Fleet angle, forced rotation
Ref. ISO4309 - 6.6.8
Action Immediate discard

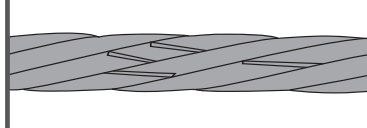

Valley wire breaks
Cause Fatigue and improper rope design
Ref. ISO4309 - 6.2
Action Discard [can be removed for limited use]

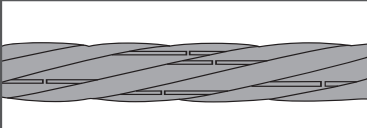

Crown wire breaks
Cause Fatigue
Ref. ISO4309 - 6.2
Action Discard [can be removed for limited use]

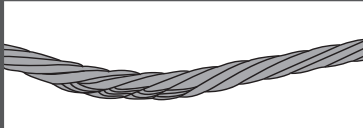

Flattened portion
Cause Rope derailing over the sheave
Ref. ISO4309 - 6.6.7
Action Immediate discard

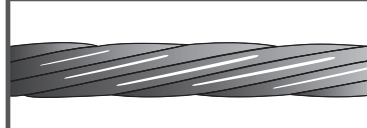

External wear
Cause Normal use
Ref. ISO4309 - 5.3.1, E2
Action Keep monitored

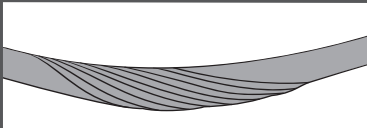

Basket deformation (birdcage)
Cause Improper installation, narrow grooves
Ref. ISO4309 - 6.6.3
Action Immediate discard

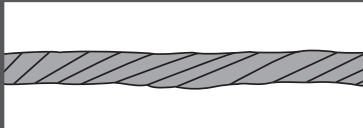

Waviness
Cause Reverse bending, rope rotation
Ref. ISO4309 - 6.6.2
Action Keep monitored



External corrosion
Cause Environment conditions
Ref. ISO4309 - 6.5
Action Keep monitored

Listed actions are for general purpose only, please contact Usha technical assistance for specific recommendations.

DISCARD CRITERIA FOR VISIBLE BROKEN WIRES

Rope conditions have to be clearly assessed by a competent person based on discard criteria provided by regulations and internal procedures. Discard criteria depend on the nature, occurrence and location of broken wires and on the rope construction and are based on number of visible broken wires, diameter variation, corrosion and distortion or a combination of all these factors.

Number of visible broken wires takes in account only the breaks due to regular use, that indicate fatigue pile up and approaching of end of rope safe life, therefore breaks due to improper handling may not be considered in this count if not affecting safety conditions.

Breaks protruding from the rope can be removed if there is the risk that they generate further damage to the equipment or to the rope itself.

If groups of broken wires are found in a section of rope which does not spool on and off the drum and breaks are concentrated in adjacent strands, it might be necessary to discard the rope.

It shall be discarded as well if two or more wire breaks are found at a termination or concentrated in the valleys in a rope lay length, as this could indicate the beginning of fatigue phenomenon.

If breaks occur randomly in rope sections running through sheaves, spooled on and off a single layer drum or on crossover points of a multilayer drum, the maximum amount is determined by specific regulations (e.g. ISO 4309). Some examples of maximum allowed breaks for different rope use and constructions are shown in the following table.

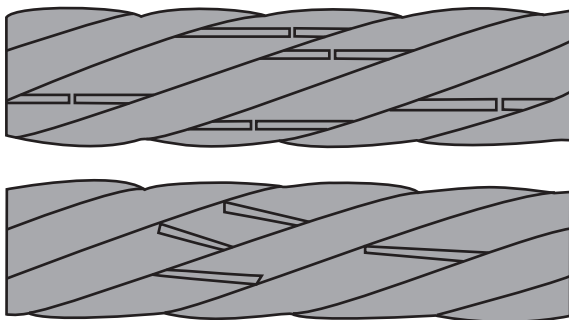

Figure 60 Crown and valley breaks due to fatigue



Rope construction	Number of visible broken outer wires					
	On steel sheaves or single layer drum				On multi - layer drum	
	Ordinary lay		Lang lay			
	Over 6d	Over 30d	Over 6d	Over 30d	Over 6d	Over 30d
6 x 19	3	6	2	3	6	12
6 x 25, 8 x 19	5	10	2	5	10	20
6 x K26, 8 x 25	6	13	3	6	12	26
6 x K36, 8 x K26	9	18	4	9	18	36
35 x 7	3	5	3	5	5	10

Figure 61 Maximum number of visible broken wires for typical rope constructions

The numbers depend on the assumption that outer wire breaks correspond to a certain number of inner wire breaks.

Typically, the number of inner broken wires due to use of a Lang lay rope is higher than the number of outer broken wires, therefore damage detection is harder and the number of outer allowed breaks must be lower.

On the other hand, in ordinary lay ropes more breaks occur on the outer surface, therefore they are more detectable and the allowed number is higher than the Lang lay value.

For non rotating ropes this difference is not remarkable due to their geometrical structure, therefore there is no distinction due to lay direction.

Breaks distribution along the rope can indicate fatigue beginning, therefore the number of broken wires over a significant rope length (e.g. 30d) is not proportional to the number of localized broken wires in a specific portion (e.g. 6d), which could be due to other causes to be specifically investigated.

DISCARD CRITERIA FOR DIAMETER DECREASE, DEFORMATION AND CORROSION

Diameter shall be periodically measured and compared to the initial reference value (i.e. recorded measurement taken immediately after receipt) to detect uniform or localized variations.

Diameter decrease has to be calculated using the below formula.

In case of uniform decrease, the maximum allowed value is 5% in respect to nominal diameter for non rotating ropes, 7.5% for other rope constructions with steel core, 10% for fibre core ropes.

A clear localized decrease indicates a severe failure of rope core and leads to immediate rope discard.

Also in case of break of a complete strand, rope has to be immediately discarded.

Ropes showing deformations like basket, core or strand protrusion or distortion, kink or tightened loop shall be evaluated and can remain in service if the damaged portion can be removed and if the remaining part of rope is still suitable for use.

Other damages, like flattened portion or permanent bend, may not be cause of immediate discard, but they have to be inspected with higher frequency, as the affected portions are likely to deteriorate and show broken wires at faster rate than usual.

Waviness should be assessed using a straight bar and considering the gap between the rope and the cut surface (see figure): the maximum allowed gap “g” is 1/3 the rope nominal diameter “d” if the deformation affects a portion not running over sheaves or spooled on the drum, otherwise it has to be reduced to 1/10.

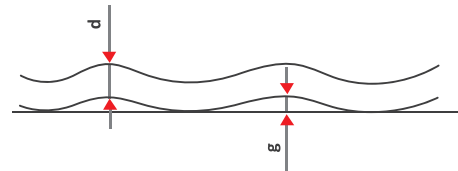

Figure 62 Waviness assessment

$$\text{Diameter decrease [\%]} = 100 \cdot \frac{\text{reference diameter} - \text{measured diameter}}{\text{nominal diameter}}$$



Corrosion should be evaluated after having wiped the rope to remove contaminating particles and should be assessed considering type and severity.

Rope should be discarded in case of heavy pitting and slack wires on the external surface, as well as in case of internal corrosion, indicated by the presence of debris extruding between the outer strands.

Rope should also be discarded in case of severe fretting corrosion, which manifests as a dry red powder and is caused by the continuous rubbing between dry wires and consequent particles oxidation.

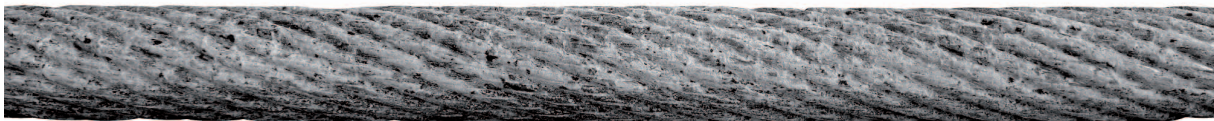

Figure 63 Rope showing external corrosion

HEALTH AND SAFETY INFORMATION

As a general indication, applicable to all types of working environment, workers must be properly trained and have all the necessary equipment and operating procedures to perform their job safely.

Steel wire rope is a composite product containing different materials, which can be identified based on the delivery note, invoice or certificate. The main component of steel wire ropes covered by the various parts of EN 12385 is carbon steel, which may be galvanized or coated with zinc aluminium alloy.

Other components can be the fibre core, the lubricant and possible plastic filling or covering. Ropes produced from carbon, galvanizing coated or stainless steel wires in the as-supplied condition are not considered a health hazard. However, during any subsequent processing such as cutting, welding, grinding and cleaning, dust and fumes may be produced which contain elements that may affect the health of exposed workers.

Fibre cores are composed by synthetic or natural fibres and do not present a health hazard when handled, except in the unlikely case that the core may have decomposed into a dust which may be inhaled.

Also the concentration of toxic fumes from the cores generated during cutting will be almost negligible compared with the products generated by wire and lubricant.

Same risk of toxic fumes inhalation applies to plastic filling or covering.

The lubricants used in the manufacture of steel wire ropes normally present minimal hazard to the user, who should anyway take reasonable care to minimize skin and eye contact and also avoid breathing their vapours and mists.



Lubricants consist essentially of mixtures of oils, waxes, bitumen, resins, petroleum jelly, gelling agents and fillers with minor concentrations of corrosion inhibitors, oxidation stabilizers and tackiness additives and they are typically solid at ambient temperature.

To avoid the possibility of skin disorders, repeated or prolonged contact with mineral or synthetic hydrocarbons should be avoided and workers should always wear protective clothing and gloves.

General and local exhaust ventilation should be used to keep airborne dust or fumes below established occupational exposure standards and operators should wear approved dust and fume respirators if these values are exceeded. Protective equipment should be worn during operations creating eye hazards, as well as gloves and other protective equipment when required. A welding hood should be worn when welding or burning.

In the solid state, steel components of the rope present no fire or explosion hazard. Organic elements, like lubricants, natural and synthetic fibres and other natural or synthetic filling and covering materials are capable of supporting fire.

Ropes and components must be disposed of in accordance with local Regulations.

APPENDIX A QUICK CALCULATOR

Quick calculation for general purpose evaluations or for preliminary design feasibility can be made using the following formulas and tables, which provide a set of relevant nominal values.

$$\text{MBF [kN]} = k \cdot d^2 \quad (d = \text{nominal diameter [mm]})$$

$$\text{Mass [kg/m]} = k_m \cdot d^2$$

$$\text{Metallic area (A) [mm}^2] = 0.785 \cdot f \cdot d^2$$

$$\text{Axial stiffness (EA) [MN]} = E \cdot 0.785 \cdot f \cdot d^2 / 1000$$

$$\text{Elastic elongation } \left[\frac{\Delta l}{l} \right] = \text{Load [kN]} / (\text{EA} \cdot 1000)$$

$$\text{Rope torque [Nm]} = t \cdot d \cdot \text{load [kN]}$$

Rope type	Fill factor (f)	MBF factor (k)	Mass factor (k _m)	E modulus [kN/mm ²]	Torque factor [t]*		Ref. lay factor (k _l)	Turn [degrees/lay]*	
					Lang	Reg		Lang	Reg
Non rotating (d up to 40 mm)	0.715	0.86 - 1.00	0.0049	127	0.02	0.009	7	2	0.5
Non rotating (d up to 100 mm)	0.725	0.86 - 0.98	0.0049	130	0.012	0.007	7	1	0
Non rotating (d over 100 mm)	0.725	0.83 - 0.86	0.0049	128	0.008	0.001	7	0.5	0
10 strands compacted spin	0.695	0.81 - 0.95	0.0047	125	0.05	0.045	6.5	14	4
10 strands compacted	0.695	0.82 - 0.96	0.0047	127	0.12	0.090	6.5	120	70
8 strands compacted	0.680	0.80 - 0.95	0.0046	125	0.11	0.085	6.5	100	60
6 strands compacted	0.670	0.79 - 0.92	0.0045	122	0.1	0.078	6.5	90	60
6 strands not compacted IWRC	0.590	0.71 - 0.85	0.0042	122	0.1	0.078	6.5	90	60

*Nominal values at 20% MBF for trained rope

1	kg/m	=	0.672	lbs/ft
1	m	=	3.28	ft
1	mm	=	0.039	inch
1	kg	=	2.205	lbs
1	lb	=	0.0005	short t [ton]
1	metric t [tonne]	=	1.10	short t [ton]
1	metric t [tonne]	=	0.984	long t
1	kN	=	0.102	metric tf
1	N/mm ² [MPa]	=	145	psi

1	lbs/ft	=	1.49	kg/m
1	ft	=	0.305	m
1	inch	=	25.4	mm
1	lbs	=	0.454	kg
1	short t [ton]	=	2000	lb
1	short t [ton]	=	0.907	metric t [tonne]
1	long t	=	1.016	metric t [tonne]
1	metric tf	=	9.81	kN
1	psi	=	0.0069	N/mm ² [MPa]



APPENDIX B

DEFINITIONS

- **BREAKING FORCE**

1. **minimum breaking force (F_{min}):** specified value in kN, below which the measured breaking force (F_m) is not allowed to fall in a prescribed breaking force test and normally obtained by calculation from the product of the square of the nominal diameter (d), the rope grade (R_r) and the breaking force factor (K)
2. **minimum breaking force factor (K):** an empirical factor used in the determination of minimum breaking force of a rope and obtained from the product of fill factor (f) for the rope class or construction, spinning loss factor (k) for the rope class or construction and the constant $\pi/4$
3. **calculated minimum breaking force (F_{c.min}):** value of minimum breaking force based on the nominal wire sizes, wire tensile strength grades and spinning loss factor for the rope class or construction as given in the manufacturer's rope design
4. **minimum aggregate breaking force (F_{e.min}):** specified value, in kN, below which the measured aggregate breaking force is not allowed to fall in a prescribed test and normally obtained by calculation from the product of the square of the rope diameter (d), the metallic cross sectional area factor (C) and the rope grade (R_r)
5. **measured aggregate breaking force (F_{e.m}):** the sum of the measured breaking forces of all the individual wires taken from the rope

6. **spinning loss factor (k):** the ratio between either the calculated minimum breaking force (F_{c.min}) and the calculated minimum aggregate breaking force (F_{e.c.min}) of the rope or the specified minimum breaking force (F_{min}) and the specified minimum aggregate breaking force (F_{e.min}) of the rope, as determined from the ropemaker's design [amended]
7. **measured total spinning loss factor (k_m):** the ratio between the measured breaking force (F_m) of the rope and the measured aggregate breaking force of the rope, before rope making

- **COATING**

1. **finish and quality of coating:** the condition of the surface finish of the wire e.g. uncoated (bright), zinc coated, zinc alloy coated or other protective coating and the class of coating, e.g. class B zinc coating, defined by the minimum mass of coating and the adherence of the coating to the steel below
2. **mass of coating:** the mass of coating (obtained by a prescribed method) per unit of surface area of the uncoated wire, expressed in g/m²

- **CORE**

1. **core:** central element of a round rope around which are laid helically the strands of a stranded rope or the unit ropes of a cable laid rope
2. **fibre core (FC):** core made from either natural fibres (NFC) or synthetic fibres (SFC) (Note - Fibre cores are normally produced in the sequence fibres to yarns, yarns to strands and strands to rope)

3. **steel core (WC):** core made from steel wires arranged as a wire strand (WSC) or as an independent wire rope (IWRC) (Note The steel core and/or its outer strands can also be covered with either fibre or solid polymer)
4. **solid polymer core (SPC):** core consisting of a solid polymer material having a round shape or a round shape with grooves. It may also contain an internal element of wire(s) or fibre

- **CROSS SECTIONAL AREA AND MASS**

1. **fill factor (f):** the ratio between the sum of the nominal metallic cross-sectional areas of all the wires in the rope and the circumscribed area of the rope based on its nominal diameter
2. **nominal metallic cross-sectional area factor (C):** factor derived from fill factor and used in the calculation to determine the nominal metallic cross-sectional area of a rope (Note - This can be expressed as $C = f \cdot \pi/4$)
3. **nominal metallic cross-sectional area (A):** the product of the nominal metallic cross-sectional area factor (C) and the square of the nominal rope diameter
4. **rope length mass factor (W):** that factor which takes into account the mass of core and lubricant as well as the metallic elements
5. **nominal rope length mass (M):** product of the length mass factor and the square of the nominal diameter

- **DIMENSIONS**

1. **dimension of round wire or strand:** the diameter of the perpendicular cross-section of the wire or strand
2. **dimension of round rope:** that diameter which circumscribes the rope cross-section
3. **outer wire factor (a):** factor used in the calculation of the approximate diameter of the outer wires of the outer strand layer
4. **outer wire diameter (δa):** the value derived from the product of the outer wire factor and the nominal rope diameter

- **GRADE AND TENSILE STRENGTH**

1. **rope grade (Rr):** a level of requirement of breaking force which is designated by a number (e.g. 1770, 1960) (Note - It does not imply that the actual tensile strength grades of the wires in the rope are necessarily of this grade)
2. **wire tensile strength grade (R):** a level of requirement of tensile strength of a wire and its corresponding range. It is designated by the value according to the lower limit of tensile strength and is used when specifying wire and when determining the calculated minimum breaking force or calculated minimum aggregate breaking force of a rope, expressed in N/mm^2
3. **wire tensile strength (Rm):** the ratio between the maximum force obtained in a tensile test and the nominal cross-sectional area of the test piece, expressed in N/mm^2



- **LAY**

1. **lay length (H):** that distance (H) parallel to the longitudinal rope axis in which the outer wires of a spiral rope, the outer strands of a stranded rope or the unit ropes of a cable-laid rope make one complete turn (or helix) about the axis of the rope
2. **lay direction of rope:** the direction right (Z) or left (S) corresponding to the direction of the outer strands in a stranded rope in relation to the longitudinal axis of the rope
3. **ordinary lay (sZ or zS):** stranded rope in which the direction of lay of the wires in the outer strands is in the opposite direction to the lay of the outer strands in the rope (Note - The first letter denotes strand direction; the second letter denotes rope direction)
4. **lang lay (zZ or sS):** stranded rope in which the lay direction of the wires in the outer strands is in the same lay direction as that of the outer strands in the rope (Note - The first letter denotes strand direction; the second letter denotes rope direction)

- **ROPES**

1. **rope construction:** the detail and arrangement of the various elements of the rope
2. **rope class:** a grouping of ropes of similar mechanical properties and physical characteristics
3. **stranded rope:** an assembly of several strands laid helically in one or more layers

around a core (single-layer rope) or centre (rotation-resistant or parallel-closed rope) (Note - Stranded ropes consisting of three or four outer strands can, or cannot, have a core)

4. **single-layer rope:** stranded rope consisting of one layer of strands laid helically around a core
5. **rotation-resistant rope:** stranded rope designed to generate reduced levels of torque and rotation when loaded (Note - Rotation-resistant ropes generally comprise an assembly of at least two layers of strands laid helically around a centre, the direction of lay of the outer strands being opposite to that of the underlying layer. Ropes having three or four strands can also be designed to exhibit rotational-resistant properties)
6. **parallel-closed rope:** stranded rope consisting of at least two layers of strands laid helically in one closing operation around a strand or fibre centre
7. **compacted strand rope:** rope in which the strands, prior to closing of the rope, are subjected to a compacting process such as drawing, rolling or swaging
8. **compacted (swaged) rope:** rope which is subjected to a compacting (usually swaging) process after closing the rope, thus reducing its diameter
9. **cable-laid rope:** an assembly of several (usually six) round stranded ropes (referred to as unit ropes) closed helically around a core (usually a seventh rope)

- **ROPE CHARACTERISTICS**

1. **torque:** torsional characteristic, the value of which is usually expressed in Nm, at a stated tensile loading and determined by test when both rope ends are prevented from rotating (Note - Torsional characteristics can also be determined by calculation)
2. **turn:** rotational characteristic, the value of which is usually expressed in degrees or turns per unit length at a stated tensile loading and determined by test when one end of the rope is free to rotate
3. **fully preformed rope:** rope in which the wires in the strands and strands in the rope have their internal stresses reduced resulting in a rope which after removal of any serving, the wires and the strands will not spring out of the rope formation

- **STRAND**

1. **strand:** an element of rope consisting of an assembly of wires of appropriate shape and dimensions laid helically in the same direction in one or more layers around a centre (Note - Strands containing three or four wires in the first layer, or certain shaped strands (e.g. ribbon) cannot have a centre)
2. **compacted strand:** a strand which has been subjected to a compacting process such as drawing, rolling or swaging whereby the metallic cross-sectional area of the wires remains unaltered whereas the shape of the wires and the dimensions of the strand are modified

3. **Seale:** parallel lay strand construction with the same number of wires in both layers
4. **Warrington:** parallel lay strand construction having an outer layer containing alternately large and small wires and twice the number of wires as the inner layer
5. **Filler:** parallel lay strand construction having an outer layer containing twice the number of wires than the inner layer, with filler wires laid in the interstices between the layers

- **WIRE**

1. **outer wires:** all wires positioned in the outer layer of a spiral rope or in the outer layer of wires in the outer strands of a stranded rope
2. **inner wires:** all wires of intermediate layers positioned between the centre wire and outer layer of wires in a spiral rope or all other wires except centre, filler, core and outer wires in a stranded rope
3. **filler wires:** wires used in filler constructions to fill up the interstices between wire layers
4. **centre wires:** wires positioned either at the centre of a spiral rope or the centres of strands of a stranded rope
5. **core wires:** all wires of the core of a stranded rope
6. **load-bearing wires:** those wires in a rope which are regarded as contributing towards the breaking force of the rope
7. **serving wire or strand:** single wire or strand used for making a close-wound helical serving to retain the elements of a rope in their assembled position



APPENDIX C

REFERENCE DOCUMENTS

The following list indicates some of the most relevant documents about wire ropes definitions, use, maintenance and inspection.

- EN 12385-1:2009 - Steel wire ropes - Safety Part 1: General requirements
- EN 12385-2:2008 - Steel wire ropes - Safety Part 2: Definitions, designation and classification
- EN 12385-3:2008 - Steel wire ropes - Safety Part 3: Information for use and maintenance
- EN 12385-4:2008 - Steel wire ropes - Safety Part 4: Stranded ropes for general lifting applications
- EN 13411-3:2011 - Terminations for steel wire ropes - Safety Part 3: ferrules and ferrule-securing
- EN 13411-4:2011 - Terminations for steel wire ropes - Safety Part 4: metal and resin socketing
- EN 13411-5:2011 - Terminations for steel wire ropes - Safety Part 5: U-bolt wire rope grips
- EN 13411-6:2011 - Terminations for steel wire ropes - Safety Part 6: Asymmetric wedge socket
- EN 13411-7:2011 - Terminations for steel wire ropes - Safety Part 7: Symmetric wedge socket
- EN12927- Part 8 - Magnetic rope testing
- ISO 17558:2006 - Steel wire ropes - Socketing procedures - Molten metal and resin socketing
- ISO 4309:2010 - Cranes - Wire ropes - Care and maintenance, inspection and discard
- IMCA M171 - Crane specification document
- IMCA M179 - Guidance on the use of cable laid slings and grommets
- IMCA M187 - Guidelines for lifting operations
- IMCA M194 - Wire rope integrity management for vessels in the offshore industry
- IMCA M197 - Guidance on non-destructive examination (NDE) by means of magnetic rope testing
- API 9A/ISO 10425:2003 - Steel wire ropes for the petroleum and natural gas industries - Minimum requirements and terms of acceptance
- API RP 9B:2005 - American Petroleum Institute recommended practice for application, care and use of wire rope for oilfield services
- Wire rope technical board - Wire rope user's manual 4th edition

APPENDIX D

EXAMPLES OF STRANDS AND ROPES CONSTRUCTIONS

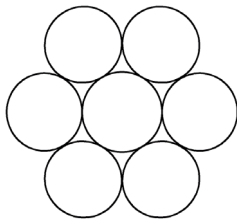

Single lay
7 (1-6)

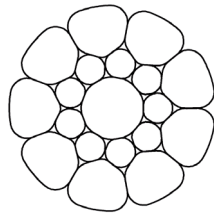

19 Seale compacted
K19S (1-9-9)

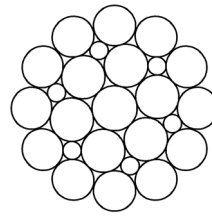

25 Filler
25F (1-6-6F-12)

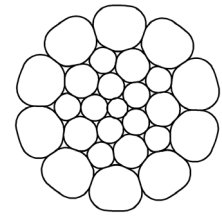

26 Warrington Seale
compacted
K26WS (1-5-5+5-10)

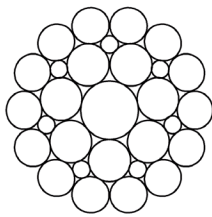

29 Filler
29F (1-7-7F-14)

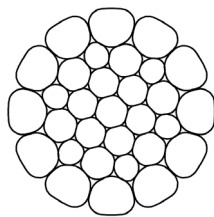

31 Warrington Seale
compacted
K31WS (1-6-6+6-12)

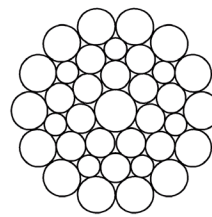

36 Warrington Seale
36WS (1-7-7+7-14)

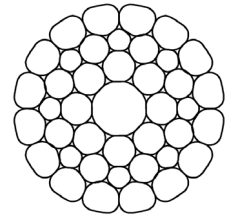

41 Warrington Seale
compacted
K41WS (1-8-8+8-16)

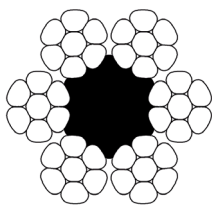

6xK7 - FC

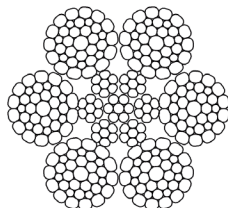

6xK36WS - IWRC

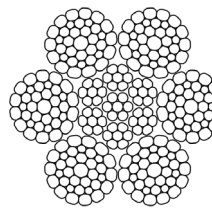

6xK36WS - PWRC

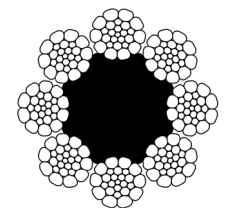

8xK26WS - FC

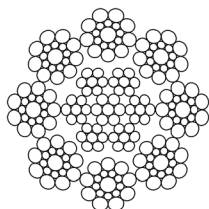

8x19S - IWRC

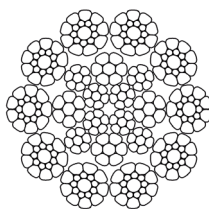

10xK19S - IWRC

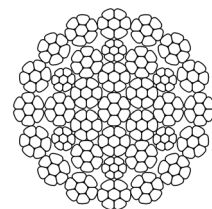

35xK7

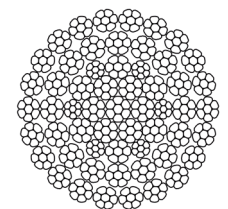

57xK7



Notes

A series of horizontal dotted lines for writing notes.



Notes

A series of horizontal dotted lines for writing notes.



Notes

A series of horizontal dotted lines for writing notes.



Notes

A series of horizontal dotted lines for writing notes.



Corporate Office
USHA MARTIN LIMITED
2A, Shakespeare Sarani
700071 Kolkata
India
Tel: +91 33 3980 0300

BRUNTON SHAW UK
Sandy Lane, Worksop
Notts, S80 3ES
United Kingdom
Tel: +44 1909 537600

DE RUITER STAALKABEL B.V.
Kerkeplaat 10
3313 LC Dordrecht
The Netherlands
Tel +31 78 8200600

USHA MARTIN AMERICAS, INC
701 Plastics Avenue
Houston, Texas 77020
United States of America
Tel: +1 713 676 1800

PT. USHA MARTIN INDONESIA
Konica Building 3A FI
Jl. Gunung Sahari Raya 78, Jakarta 10610
Indonesia
Tel: +62 21 428 70794

BRUNTON WOLF WIRE ROPES FZCO
P.O. Box 17491, M00301
Jebel Ali Free Zone
Dubai, U.A.E.
Tel: +971 04 883 8151

EUROPEAN MANAGEMENT & MARINE CORP
Howe Moss Place, Dyce
AB21 0GS, Aberdeen
United Kingdom
Tel: +44 1224 775151

Global Design Centre
USHA MARTIN ITALIA srl
Via Nikolajewka 1
25062 Concesio (BS)
Italy
Tel: +39 030 218 8345

USHA SIAM STEEL LIMITED
209 K-Tower-B, 22nd Floor
Unit 3/1 Sukhumvit 21 Road
Bangkok 101110, Thailand
Tel: +66 2 261 7361

USHA MARTIN UK LIMITED
Tasman House, Mariner Court
G81 2NR, Clydebank
United Kingdom
Tel: +44 141 951 8801

USHA MARTIN CHINA CO. LTD.
No 122, East Fu Te No1 Rd
Wai Gao Qiao Free Trade Zone, 20031
Shanghai, P.R. China
Tel: +86 21 6858 8699

USHA MARTIN VIETNAM CO. LTD
Unit 201, 18A, D2 Street, Ward 25
Binh Thanh Dist. Ho Chi Minh City,
S.R. Vietnam
Tel: +84 8 3512 2209

USHA MARTIN AUSTRALIA PTY LTD
Unit 2/ 468-470, Victoria Street
St Wetherhill Park, NSW 2164
Australia
Tel: +61 296 094971

USHA MARTIN SINGAPORE PTE LTD
91 Tuas Bay Drive,
Usha Martin Building, 637307
Singapore
Tel: +65 6265 7756

USHA MARTIN ITALIA S.R.L.
Via Nikolajewka 1 - 25062 Concesio (BS) ITALY
info@ushamartin.it